

MENU

ENTER

- INPUT
- MODE
- CLIP
- SIGNAL
- CLIP
- SIGNAL
- DSP
- Uman

3.1 Signal Monitor



CAMCO V8



V8

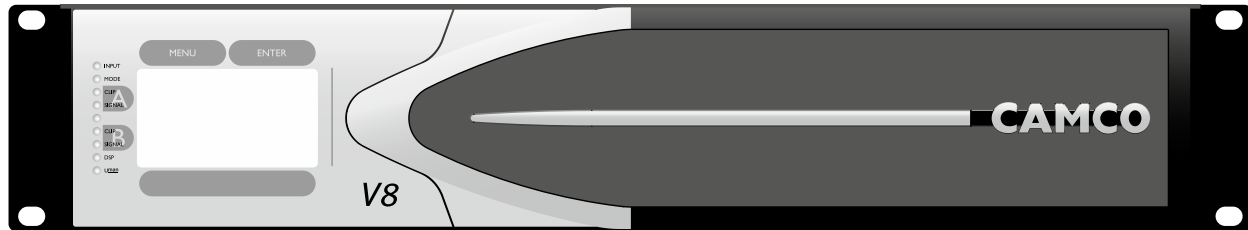
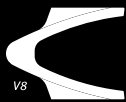

INFORMATION FOR USE FOR MODELS *VORTEX SILVER SERIES V8*

SSUM_GB_2010-2012-R4_12-2012

The leading version of this brochure is the English one which shall prevail to the exclusion of the national translation on hand.

Copyright 2010–2012 by **CAMCO** Produktions- und Vertriebs-GmbH
für Beschallungs- und Beleuchtungsanlagen
Fischpicke 5, 57482 Wenden, Germany
Telephone +49 (0) 27 62 408-0

VORTEX SILVER SERIES

Please visit our website www.camcoaudio.com for the latest version of this user manual. Please note that the leading version of CAMCO manuals is always the English one.

IMPORTANT SAFETY INSTRUCTIONS

1. General

The amplifier may only be used in accordance with the information provided in the user manual. Before and during the usage of the amplifier please ensure that all recommendations, especially the safety recommendations as detailed in the user manual, are adhered to.

The **VORTEX SILVER SERIES V8** amplifier is designed for the amplification of pulsed audio signals. The amplifier should only be connected to speakers with an average impedance as indicated.

2. User Manual

Read the information for use (user manual) and heed all warnings. Keep this user manual in a safe place during the lifetime of the amplifier. The user manual forms an integral part of the amplifier. Reselling the amplifier is only possible if the user manual is available. In case of reselling the amplifier, the reseller has to document any changes made to the amplifier in writing and pass the documentation on to the buyer.

3. Environments

Use this amplifier only in E1, E2, E3, or E4 environments according to EN55103-2 "Electromagnetic compatibility – Product family standard for audio, video, and audio-visual and entertainment lighting control apparatus for professional use – Part 2: Immunity".

4. Mounting/Placement

Do not place this amplifier on an unstable cart, stand, tripod, bracket, or table. The amplifier may fall causing serious injury and serious damage to the product. Any mounting of the amplifier should follow the manufacturer's instructions. Only mounting accessory shall be used which is recommended by the manufacturer.



5. Power Cord Protection

Power supply cords should be routed so that they are not likely to be walked on or pinched by items placed upon them or against them, paying particular attention to cords and plugs and the point where they exit from the amplifier.

6. Heat

Do not use this amplifier near any heat sources such as radiators, heat registers, stoves, or other apparatuses that produce heat.

7. Water and Moisture

Do not expose this device to rain or moisture. Do not use this amplifier near water (for example swimming pools and fountains). Do not place any objects containing liquids, such as bottles or glasses, on the top of the unit. Do not splash liquids on the unit. IP-20 equipment. There is no protection against splashing water.

8. Ventilation

Slots and openings in the cabinet are provided for ventilation to ensure reliable operation of the amplifier and to protect it from overheating. These openings must not be blocked or covered. This amplifier should not be installed unless proper ventilation is provided or manufacturer's instructions have been adhered to.

9. Interference Of External Objects and/or Liquids with the Appliance

Never push objects of any kind into this amplifier through openings as they may touch dangerous voltage points or short-out parts that could result in fire or electric shock. Never spill liquid of any kind on the amplifier.



10. Connections

When you connect the amplifier to other equipment, turn off the power and unplug all of the equipment from the supply source. Failure to do so may cause an electric shock and serious personal injury. Read the user manual of the other equipment carefully and follow the instructions when making the connections.

11. Lightning

For additional protection of this amplifier during lightning storms or when it is left unattended and/or unused for long periods of time, unplug it from the wall outlet. This will prevent damage to the amplifier due to lightning and power line surges. Disconnection from the mains power supply can only be achieved by removing the plug from the mains socket and by external disconnecting all poles from the mains.

12. Damages that Require Service

Unplug this amplifier from the mains supply and refer to your dealer/distributor or other authorized repair workshop if any of the following situations occur:

- if liquid has been spilled or objects have fallen into the amplifier
- if the amplifier has been exposed to rain or moisture
- if the amplifier has been dropped or damaged in any other way
- if the power supply cord or plug has been damaged
- when the amplifier exhibits a distinct change from its normal function or performance
- in case the amplifier has been used in a dusty environment for quite a period of time

13. Servicing

All service and repair work must be carried out by a dealer/distributor authorized by **CAMCO**. Do not attempt to service this amplifier yourself. As opening or removing covers may expose you to dangerous voltage or other hazards, the amplifier may only be opened by qualified personnel. Please refer to your dealer/distributor.

14. Spare Parts

When spare parts are required, please ensure that the dealer/distributor only uses spare parts specified by the manufacturer. The use of unauthorized spare parts may result in injury and/or damage through fire or electric shock or other electricity-related hazards.

15. Safety Check

Upon completion of any service or repairs to this product, ask the dealer/distributor to perform safety checks to determine that the amplifier works properly.

Recommendations on how to carry out the safety test can be found in DIN VDE 0701-1 "Maintenance, Modification and Test of Electronic Appliances".

16. Cleaning

Unplug this amplifier from the wall outlet before cleaning. Do not use liquid or aerosol cleaners. Clean only with dry cloth.

17. Packaging and Shipping

When shipping the **VORTEX SILVER SERIES V8** amplifier, always use the original shipping carton and packing materials. For maximum protection repack the unit as it was originally packed at the factory.



CAUTION
RISK OF ELECTRIC SHOCK
DO NOT OPEN



CAUTION – HIGH VOLTAGE HAZARDS
EXIST WITHIN THIS PRODUCT.
REFER ALL SERVICING TO
AUTHORIZED PERSONNEL.



THE LIGHTNING FLASH WITH ARROW HEAD SYMBOL IS INTENDED TO
ALERT THE USER TO THE PRESENCE OF UNINSULATED DANGEROUS
VOLTAGE WITHIN THE PRODUCT'S ENCLOSURE.



THE EXCLAMATION MARK IS INTENDED TO ALERT THE USER
TO IMPORTANT INSTRUCTIONS ALSO FOR MAINTENANCE IN THE
LITERATURE ACCOMPANYING THE AMPLIFIER.



THE LIGHTNING FLASH WITH ARROW HEAD SYMBOL ALERTS
THE USER TO DANGEROUSLY HIGH VOLTAGE AT THE OUTPUT
CONNECTORS! THAT COULD POTENTIALLY BE LIFE THREATENING.

CAUTION – RISK OF ELECTRIC SHOCK – DO NOT OPEN.

WARNING – TO PREVENT FIRE OR SHOCK HAZARD, DO NOT
EXPOSE THIS AMPLIFIER TO RAIN OR MOISTURE.



THE AMPLIFIER MAY ONLY BE CONNECTED
TO A SOCKET WITH A PROTECTIVE EARTH CONDUCTOR.



EC Declaration Of Conformity In Accordance To EC Directives:
electromagnetic compatibility (Council Directive 2004/108/EC,);
low-voltage electrical equipment (Council Directive 2006/95/EC)

Manufacturer's Name:

CAMCO Produktions- und Vertriebs-GmbH
für Beschallungs- und Beleuchtungsanlagen

Manufacturer's Address:

Fischpicke 5, 57482 Wenden, Germany

Declares That The Product With The Model Name:

CAMCO Power amplifier **VORTEX SILVER SERIES V8**

Conforms To The Following Standards:

- EN60065 Safety
- EN55103-1 Emission
- EN55103-2 Immunity

The operating conditions and application environments presupposed in the information for use (user manual) are to be kept to accordingly.

Please Note: The following formulations have been chosen: **VORTEX-V8** for the type plate and for the EC declaration of conformity. **V8** for the front face of the appliance and for the text in the user manual.

Wenden, 13.03.2012



Joachim Stöcker



P. 2	IMPORTANT SAFETY INSTRUCTIONS	P. 18	4.3 Indicators	P. 31	8 SERVICE INFORMATION
P. 4	EXPLANATION OF SYMBOLS	4.3.1	Input Selection LED	P. 32	9 MAINTENANCE INFORMATION
P. 5	EC DECLARATION OF CONFORMITY	4.3.2	Output Mode LED	10	DECOMMISSIONING
P. 6	CONTENTS	4.3.3	Clip LED	P. 33	COMPANY INFORMATION
P. 7	1 WELCOME	4.3.4	Signal LED	P. 34	NOTICES/CHANGES MADE TO THE AMPLIFIER
	1.1 Welcome To CAMCO	4.3.5	Device Identifier LED		
P. 8	2 THE AMPLIFIER	4.3.6	DSP LED		
	2.1 Unpacking	4.3.7	Uman LED		
	2.2 The Amplifier	P. 19	4.4 Main Menu		
P. 9	2.3 V8 – The Front	4.5	Power Amp Protection Systems		
	2.4 V8 – The Rear	4.5.1	Clip Limiter		
P. 10	2.5 Factory settings	4.5.2	SOA Protection		
	3 INSTALLATION	4.5.3	Thermal Protection		
	3.1 Mounting	P. 20	4.5.4 DC Protection		
P. 11	3.2 Cooling	4.5.5	DC Servo		
	3.3 Mains	4.5.6	Overcurrent Protection		
	3.3.1 Mains supply	4.6	Mains Protections		
P. 12	3.3.2 Inrush current limitation	4.6.1	Inrush Current Limitation		
	3.3.3 Mains power consumption and current draw	4.6.2	Mains Overvoltage Detection		
P. 13	3.4 Signal inputs	4.6.3	Mains Surge Overvoltage Protection		
	3.4.1 Analog Input	P. 21	4.9.4 Fuse Protection		
	3.4.2 AES Input	4.7	Main SMPS Protections		
	3.4.3 Uman Input/Output	4.7.1	Overcurrent Protection		
	3.5 Remote control inputs (Ethernet/Uman)	4.7.2	Overload Protection		
P. 14	3.6 Power Outputs	4.7.3	Thermal Protection		
	3.6.1 SPEAKON® Connection	4.8	Fans		
P. 15	3.6.2 Dual Channel Operation	P. 22	4.9 Internal LED Description		
	3.6.3 Parallel Mono Operation	P. 23	4.10 Filter Cleaning		
	3.6.4 Mono Bridge Operation	P. 24	5 SPECIFICATION		
P. 16	4 OPERATION	P. 27	6 TYPICAL PERFORMANCE DIAGRAMS		
	4.1 Screen User Interface	P. 30	7 WARRANTY INFORMATION		
	4.1.1 Screen User Interface Elements	7.1	Summary of Warranty		
	4.1.2 Handle the Selection Bars	7.2	Items Excluded from This Warranty		
P. 17	4.1.3 Hot Key Functions	7.3	What CAMCO Will Do		
	4.2 Power On/Off	7.4	How to Obtain Warranty Service		
		7.5	CAMCO 's Product Improvement		



1.1 Welcome To CAMCO

Established in 1983, **CAMCO** has gained worldwide experience with professional sound reinforcement technology. Within the audio market, **CAMCO** specialises in the production and marketing of high quality power amplifiers and sound systems to be used both on tour and in static installations.

The success of the **LA**, **DL**, **DX**, and **TECTON** series power amps has made the name **CAMCO** synonymous with professional quality, high performance, and utterly reliable power amps.

With the **VORTEX** power amp series, **CAMCO** has been pioneering a new dimension in professional power amp construction in the last decade. The seamless combination of ground-breaking technology with proven safety elements has been the hallmark of the **VORTEX** series.

CAMCO's commitment to research and development, seen not just in the area of materials and technology but also most importantly in its highly skilled and motivated workforce, is one of the keys to its ongoing success.

The new technologies that have been developed and applied to the pro-audio industry have been substantial over the last few years, but actually it is only now that we as designers, researchers, and developers are able to take the next steps in building a more coherent future with tools that really integrate together.

The ancient cultures developed an understanding of our world by a realisation of the individual elements that are at the core of all things. These were described as the Five Elements. We see the development of technology and the resulting products in the same way. Today **CAMCO** follows the same pattern of realisation, our five elements are ; Efficiency, Power, Networking, Signal Processing, and Design.

As the five elements come together to form the One, we can see that the evolution of amplifiers is now reaching the point where we can truly call the amplifier a universal audio platform, not just X-amount of power output, as impressive as it is in terms of true power per channel across the **V8**, but a Network station, an advanced Signal Processing station, a multicore like distribution centre, too, allowing hundreds of channels of processing and data to be sent and received which all can be controlled from one platform.

Thus the efficiency of the complete package now shows itself to be much more than just a power amplifier. The **CAMCO VORTEX SILVER SERIES V8** is evolving into much more; it is in fact becoming the evolution of today's pro-audio needs and conditions. It will be the bench mark for building the future.

Welcome to the new world of professional power amplifiers –

WELCOME TO CAMCO!

2.1 Unpacking

Please unpack and inspect your new amplifier for any damage that may have occurred during transit. If damage is found, notify the transportation company immediately. Only you as the consignee may initiate a claim for shipping damage. **CAMCO** will be happy to cooperate fully as needed. Please save the shipping carton as evidence of damage for the shipper's inspection.

Even if the amplifier has arrived in perfect condition, save all packing materials for any future transport of the unit.

When shipping the **V8** amplifier, always use the original shipping carton and packing materials. For maximum protection, repack the unit as it was originally packed at the factory.

NOTE: Never ship the amplifier without the original packaging materials.

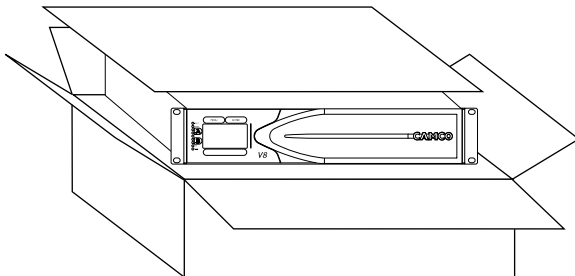

2.2 The Amplifier

The **V8** amplifiers offer a power output of:

- 4900 W peak per channel @ 4 Ω
- 5300 W peak per channel @ 2 Ω
- 10600 W peak in Mono Bridge @ 4 Ω
- 10600 W peak in Parallel Mono @ 1 Ω

Using a bipolar class H high efficiency power amplifier output stage. For a complete overview of rated power data please refer to chapter 8 Specifications.

The **V8** power amplifier is fitted with Dual Voltage Switched Mode Power Supply (SMPS) with automatic voltage range selection for 120 V / 230 V operation, which significantly reduces the weight and size (only 2U) of the amplifier. Using SMPS, the seamlessly regulated symmetrical supply voltages of the power amplifier are more stable and efficient than the power supplies used in conventional amplifiers.

The **V8** also uses a microprocessor for controlling and monitoring the power amp. This has five main advantages over more traditional power amp systems:

1. Integrated Remote Control
2. Extreme fast and accurate monitoring of all amplifier parameters
3. Fast detection of failures
4. Very fast triggering of protection features
5. Very detailed indication of failures on the display

The **V8** has been designed as an intelligent and powerful amplifier for performing specialised tasks within a complex audio system. Users can adapt the power amp to meet their specific audio requirements before use. The display mounted on the front of the **V8** amplifier allow the different functions to be accessed. Since there are a lot of parameters available, it is important that users should familiarize themselves thoroughly with the entire range of settings and programmable features before using the power amp. If you have any questions regarding features and/or functions of your **V8** amplifier, **CAMCO** will be pleased to provide you with further information. Alternatively, contact your dealer or distributor.

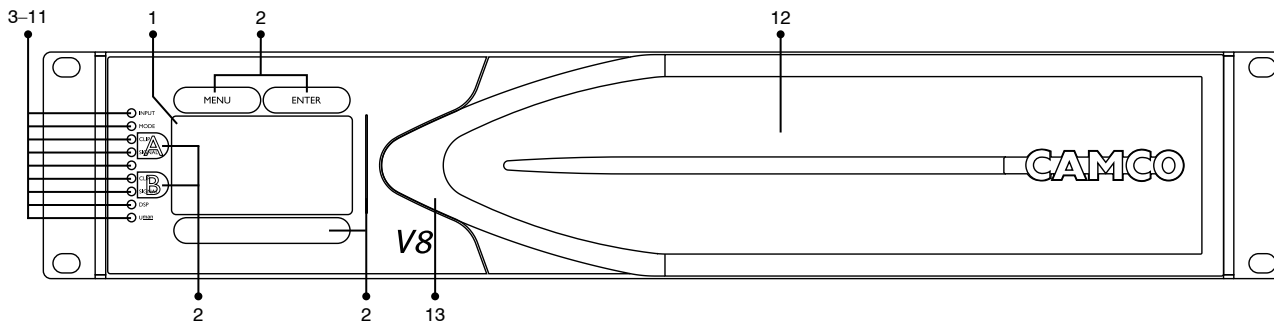

2.3 V8 – The Front

- 1 Display
- 2 Touch Controls
- 3 Input Selection LED
- 4 Output Mode LED
- 5 Clip LED Channel A
- 6 Signal LED Channel A
- 7 Device Indicator LED

- 8 Clip LED Channel B
- 9 Signal LED Channel B
- 10 DSP LED
- 11 Uman Network Status LED
- 12 Cooling Air Inlet Vents
- 13 Removable Air Filter System

2.4 V8 – The Rear

- 14 AC Power Connector
- 15 SPEAKON® Connectors
- 16 Cooling Air Outlet Vents
- 17 XLR – Line Inputs
- 18 XLR – Line Link Outputs (passive loop-through)

- 19 Uman Network Connectors
- 20 Uman Network Link LEDs
- 21 Ethernet Connector for remote access
- 22 Digital AES/EBU XLR Input

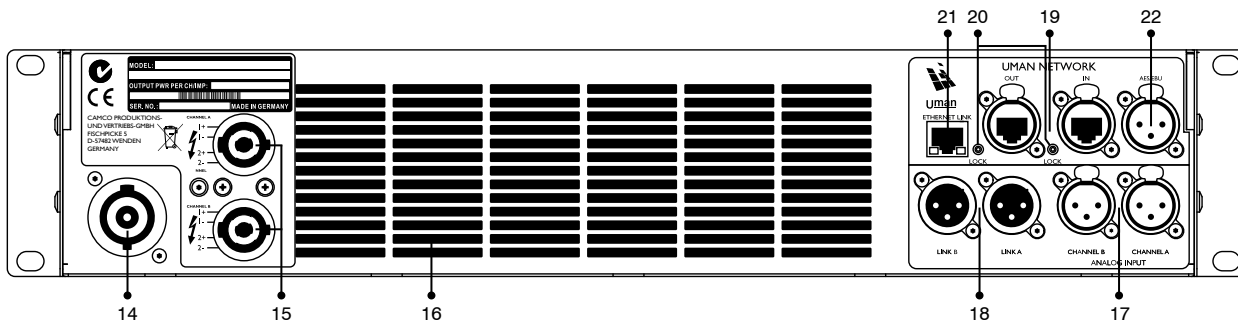

2.5 Factory settings

V8 amplifiers are delivered with the following factory settings

Power Status	Amplifier is switched Off
Input Selection	Analog
AmpGain	32 dB
Output Mode	Dual Channel
Mute	Both channels active (unmuted)
Level Attenuator	0 dB both channels
Clip Limiter	Off
DSP	Off
Lock Device	Unlocked
Ethernet Settings	192.168.1.20
Ethernet Mask	255.255.255.0
Ethernet Gateway	192.168.1.200
<u>Uman</u> IP	192.168.20.1
<u>Uman</u> Mask	255.255.255.0
<u>Uman</u> Gateway	192.168.20.1
FuseProtect level	24 A

In the settings menu there are three options to restore the original factory settings.

1. The reset "Settings" option will restore all amplifier parameters and a reboot of the amplifier will take place. Note that this type of reset is also done at the end of each a firmware update process.
2. The "Settings+IP" option will do the same but additionally also restore the Ethernet and Uman network IP settings to the above values.
3. The third option "Settings+IP+Presets" will additionally **delete all** previously stored or downloaded **DSP presets**, leaving the amplifier with a blank (empty) preset memory. So please don't forget to make a backup of all your user defined presets before choosing this option.

3.1 Mounting

Use four screws and washers when mounting the amplifier to the front rack rails. For mobile use, the amplifier should also be secured using the 19" mounting elements on the rear panel.

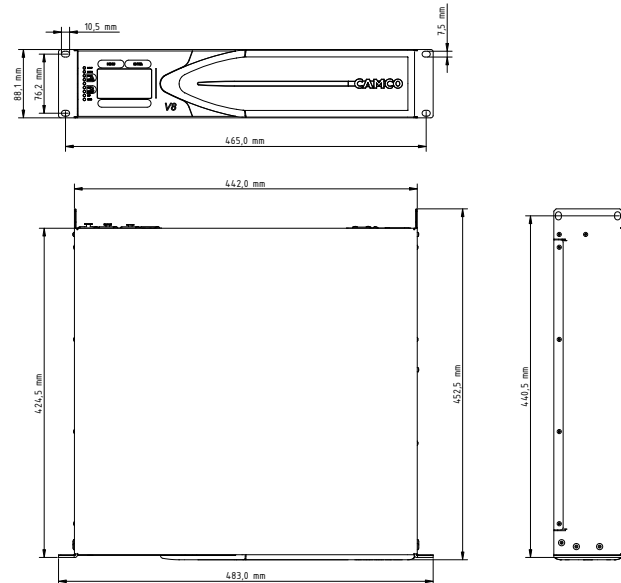

3.2 Cooling

Under normal operation of the power amp, overheating should never be a problem. The air is taken in from the front and out through the back. It is of course essential that, while the power amp is running, the air is able to circulate around it freely. The efficiency of the cooling will depend on both the immediate environment (e.g. an enclosed rack, direct sunlight) and that the front filter is clogged. If the amp is installed in a case, the open area at the back of the case must be at least 140 cm². This area should be in line with the amp. If this cannot be achieved, a forced ventilation system has to be used.

3.3. Mains

3.3.1 Mains supply

Only connect the **V8** amplifier to an appropriate AC circuit and outlet in accordance with the requirements indicated in the second line on the rating plate. Only use mains cables with original Neutrik powerCON[®] 32 A connectors for safety reasons.

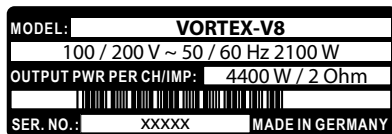
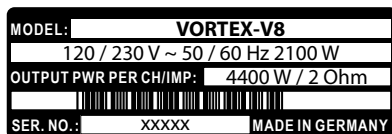

For installation mains cable and amplifier protection, we recommend the use of a 16 A mains breaker with C-type tripping characteristic for 230 V operation for *each* **V8** amplifier! (or a 30–32 A breaker for 120 V operation respectively)

Please do NOT use much larger mains breakers than recommended here and especially do NOT connect several V8 amplifiers to one single (very large) breaker.

Always respect this rule of thumb for good installation practice for guaranteeing long term reliable, robust and safe operation:

One V8 – One breaker

As soon as the amplifier is connected to mains, the primary capacitors are charged through the inrush current limiter. At the same time the the auxiliary power supply is activated, generating a 5 V standby voltage to the main controller and the display. This allows powering up the main SMPS from the display or remotely via Uman or an ethernet network connection.

NOTE: Turning the amplifier off from the user interface (display) does not disconnect the amplifier from mains.

Disconnecting the amplifier from the mains can only be achieved by physically removing/disconnecting the mains cable. The mains cable therefore has to be freely accessible at all times.

Attention: Never unplug the powerCON[®] connector while the amplifier is playing music. Always turn the amplifier off from the display menu (see *chapter 4.2*) before disconnecting the powerCON[®] connector.

Alternatively, you can disconnect the amplifier from the mains via an external all-pole disconnection (e.g. a mains breaker).

Disconnect the mains cable during a lightning storm or when the amplifier remains unused or unsupervised for a prolonged period of time.

If a power cut occurs while the amplifier is switched on, it will restart automatically once the mains distribution has been restored. All settings prior to the loss of power will be maintained.



3.3.2 Inrush current limitation

The **V8** has a special processor dedicated to limit the mains inrush current.

This limiter will take action anytime:

- when connecting the amplifier to the mains through the mains cable
- when switching the amplifier on through an external mains breaker
- the mains voltage was lost for at least 4 half-cycles or more (e.g. a short voltage drop)

This limiter will confine the mains current to a value smaller than 17 A_{rms}*.

*: maximum rms value of inrush current over one half-cycle of the mains voltage according to DIN EN 55103-1.

NOTE: Even under normal conditions the mains current can reach levels up to 32 A/64 A (230 V/120 V) and even higher for very short periods of time. This could cause lamps to flicker if connected to the same mains as the amplifier. The impedance of the AC circuit should be less than 0,157 Ω to avoid flicker according to EN61000-3-11 “Electromagnetic compatibility – Part 3-11: Limits – Limitation of voltage changes, voltage fluctuations, and flicker in the public low-voltage supply systems – Equipment with rated current ≤ 75 A and subject to conditional connection”. If in any doubt, consult your local power provider. Never attempt to measure this impedance level with your ohmmeter. This may damage your meter and expose you to the risk of electric shock!

3.3.3 Mains power consumption and current draw

Due to the huge output power of the **V8**, the mains current draw can get very high when demanding large output powers. Please refer to following table for an overview of mains currents and power consumption under different operating conditions.

Operating condition	Mains current (4 Ω/2 Ω)	Power consumption (4 Ω/2 Ω)	Output power
Amplifier standby (power off)	< 0,4 A	8 W	0 W
Idle (amplifier powered on)	1 A	60 W	0 W
300 W per channel	8,4/9,2 A	1120/1250 W	600 W
600 W per channel / 1/8th	13,4/14,9 A	1930/2150 W	1200 W
1200 W per channel* / 1/4th	22,4/25,3 A	3360/3830 W	2400 W
1600 W per channel* / 1/8rd	29,4/32,3 A	4570/4950 W	3200 W

Mains current draw and power consumption @ 230 V, 50 Hz

Measured with pink noise with crest factor of 12 dB to represent typical music signal.

For 120 V mains operation, the current values can be multiplied by 2.

*: duration limited by FuseProtect limiter (set @ 24 A)

Please note that the values given here are typical values only, measured on a standard 230 V/50 Hz outlet. The actual mains current draw can vary depending on the music signal and the mains characteristics (especially the mains impedance) of any specific installation.

The integrated FuseProtect limiter will limit the average mains current draw to values between 24 A down to 8 A (selectable in 1 A steps).

This allows to control the average (long-term) mains current draw of your installation, while at the same time guaranteeing full power headroom for dynamic music signals.

This means that even if the FuseProtect limiter is set to low average values, the short term mains current draw can still reach very high levels, especially when delivering huge output power with very dynamic music signals.

Please see chapter 4.6.5 for more information on the FuseProtect limiter.

3.4 Signal inputs

The **V8** amplifier offers three different input signal sources:

Analog

In this mode the analog signals connected to the XLR input connectors will be used as input signal. In analog mode the **V8** has **no** signal latency (with DSP switched off), the audio signal path is pure analog.

AES

In this mode the digital AES input signal connected to the AES XLR input connector will be used as input signal.

Uman

With the Uman setting the input signals are taken from the Uman Digital Audio Network Interface.

3.4.1 Analog Input

XLR: Pin 1 = Ground (lifted via 15 Ω resistor to chassis/earth)

Pin 2 = Hot (in-phase, "+")

Pin 3 = Cold (out of phase, "-")

We suggest to always use symmetrically (balanced) shielded cable to connect the amplifier.

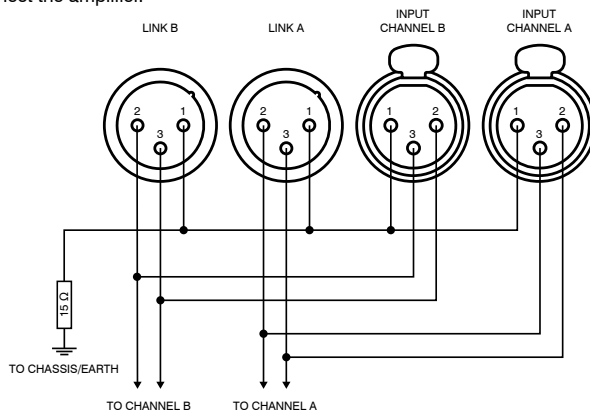

The **V8** amplifier has a 26 dB and 32 dB voltage gain setting along with a 1,4 V sensitivity setting.

The table shows input sensitivity per channel for a given gain and load. It also shows the gain for the 1,4 V input sensitivity.

Model	rated output power	26 dB	32 dB	1,4 V
V8	5100 W @ 2 Ω 4000 W @ 4 Ω 2300 W @ 8 Ω	5,08 V 6,38 V 6,80 V	2,54 V 3,19 V 3,40 V	40 dB

3.4.2 AES Input

The digital AES XLR input accepts any AES/EBU signals (pro or consumer format) in 16, 18, 20 or 24 bit resolution and from 32 to 192 kHz sampling frequency. This wide input frequency range of is guaranteed by an integrated sample rate converter (SRC) chip.

3.4.3 Uman Input/Output

The Uman input and output connectors allow you to receive and send multichannel digital audio streams to other Uman-compatible devices (like other **V8** amplifiers for example). Please note that although the Uman connectors use the same connector type than standard Ethernet (RJ-45), the physical transmission protocols are different. So any direct connection between the Uman connectors and standard Ethernet connectors will not work.

3.5 Remote control inputs (Ethernet/Uman)

The Ethernet Link network connector allows you to access the **V8** from a host computer for remote control, firmware update and downloading DSP presets. Please note that for setting up proper network connection we suggest to use the **CAMCO** NetSetup-Tool. This tool automatically sets up the needed network settings on your host computer for seamless communication.

If you want to connect more amplifiers (to one amplifier already connected through the Ethernet Link) you can do so by connecting them to

this first amplifier through the Uman input and output connectors (daisy-chaining). The first **V8** amplifier connected by Ethernet then acts as an Ethernet to Uman bridge for remote control purposes.

3.6 Power Outputs

3.6.1 SPEAKON® Connection

Both SPEAKON® connectors are connected to the channel A and channel B amplifier outputs. Note that the wiring configuration of the second (bottom) SPEAKON® connector is inverted (channel A and B outputs swapped).

The pin configuration of the SPEAKON® connectors is as follows:

Upper SPEAKON®:

Pin 1+	Channel A amplifier output
Pin 1-	Channel A ground
Pin 2+	Channel B amplifier output
Pin 2-	Channel B ground

Bottom SPEAKON®:

Pin 1+	Channel B amplifier output
Pin 1-	Channel B ground
Pin 2+	Channel A amplifier output
Pin 2-	Channel A ground

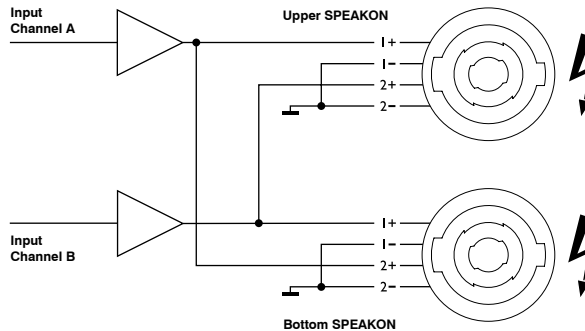

WARNING!

SPEAKON® connectors marked with the lightning flashes indicate high voltages that are potentially life threatening.

Wiring to these terminals requires installation by an instructed person or the use of ready-made leads or cords.

Custom wiring should only be carried out by qualified personnel.

To prevent electric shock, do not operate the amplifier with any of the conductor portion of the speaker wire exposed.

NOTE: For reasons of safety and performance do only use high-quality fully insulated speaker cables of stranded copper wire. Use the largest wire size that is economically and physically practical. Make sure that the cables are not longer than necessary.

IMPORTANT: When connecting speaker cabinets in parallel (especially in Paralell Mono operation mode), always use both SPEAKON® connectors where possible for current sharing. Not doing so may cause permanent damage to the connectors and may considerably reduce performance.

3.6.2 Dual Channel Operation

Two fully independent amplifier channels (aka “Stereo” – normal operating mode).

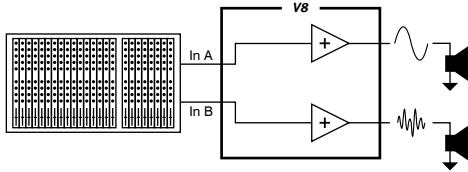

$Z_{min} = 2 \Omega$ for Dual Channel operation

3.6.3 Parallel Mono Operation

Parallel operation of both amplifier channels.

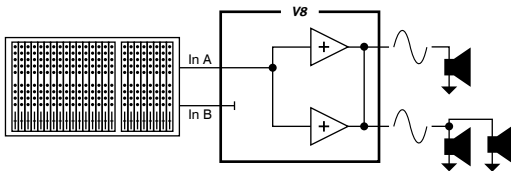

$Z_{min} = 1 \Omega$ for Parallel Mono operation

The amplifier outputs of the two channels are switched together (in parallel) using an internal relay. This effectively doubles the current capability of the amplifier, allowing to connect lower output impedances.

In this mode only the channel A input signal is fed to both amplifiers. The channel B input signal is not used/ignored.

The loudspeaker loads can then be connected to either the channel A or the channel B output SPEAKON® connectors (we still recommend to always use both). This mode is useful when for example 3 identical loudspeakers are to be operated with the same power.

When connecting speaker cabinets in parallel, always use both SPEAKON® connectors where possible for current sharing. Not doing so may cause permanent damage to the connectors and may considerably reduce performance.

3.6.4 Mono Bridge Operation

One-channel mono bridged operation.

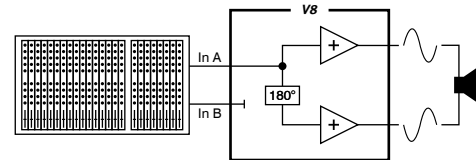

$Z_{min} = 4 \Omega$ for Mono Bridge operation

In this mode the channel B amplifier stage processes the identical input signal than channel A, but with reversed phase.

The loudspeaker load must then be connected between the two positive channel outputs (pin 1+ and pin 2+) using a specially configured SPEAKON® connector/cable. This effectively doubles the maximum output voltage. But please note that this also doubles the minimum allowed loudspeaker impedance Z_{min} .

As in parallel mono operation, only the channel A input signal is fed to both amplifiers. The channel B input signal is not used/ignored.

WARNING: In Mono Bridge Operation RMS output voltages can be as high as 280 Vac. Wiring to the speaker loads must conform to NEC Class 3 safety standards or its equivalent that meets all national and local electric codes. All customer specific cables may only be manufactured by qualified suppliers/personnel. All cabling or rewiring work must be carried out by qualified personnel.

4.1 Screen User Interface

Due to the advanced approach with the absence of any control knobs or switches, control of all parameters is done via the screen user interface.

4.1.1 Screen User Interface Elements

The screen user interface consists of four buttons and two selection bars.

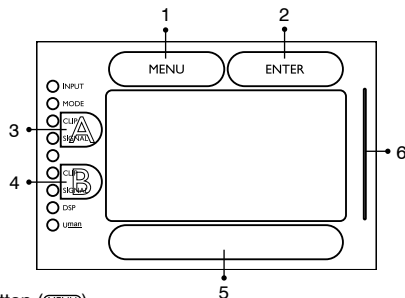

1 MENU button (MENU)

- Touch shortly to leave the current screen without changes
- Shortcut key: touch and hold (≈ 2 s) to access the Home Menu

2 ENTER button (ENTER)

- Navigate to the selected menu item, activate selected items, confirm changes
- Shortcut key: touch and hold (≈ 2 s) to access the Quick Access Menu

3 A button (A)

- Select channel A related parameters

4 B button (B)

- Select channel B related parameters
- Note: The **A** and **B** buttons must always be touched a little longer than others before the action takes effect

5 Horizontal Selection Bar (HSB)

- Decrease/increase values (left/right)

6 Vertical Selection Bar (VSB)

- Scrolls through menu items (up/down)

4.1.2 Handle the Selection Bars

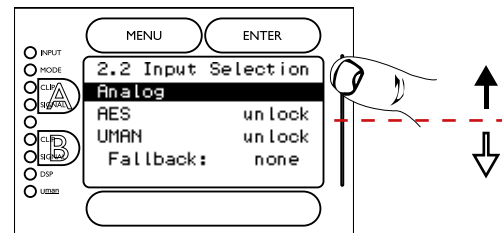

- Tip the VSB at the upper half to scroll upwards.
- Tip the VSB at the lower half to scroll downwards.

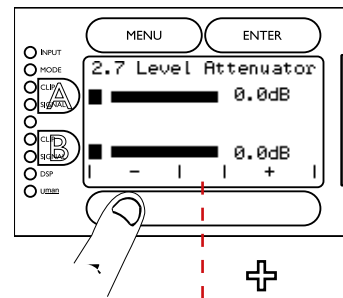

- Tip the HSB at the left half to decrease values.
- Tip the HSB at the right half to increase values.



4.1.3 Hot Key Functions

The Hot key Functions give you a quick access to your favorite screens and some special features:

Power Off Hot Key (accessible from all menus and screens):

Touch and hold **MENU** and **ENTER** simultaneously (≈ 3 s). The Power Off screen will be displayed. Holding longer (or touching and holding again **MENU** and **ENTER**) will display the power off confirmation window.

Level Attenuator Hot Key (accessible from all monitor screens):

Touching the **HSB** (left/right) opens the Level Attenuator Screen for a quick access to level adjustments. After adjustment you can step back to the previous screen by touching the **MENU** button.

Scroll Monitor Menus Hot Key (accessible from all monitor screens):

Touching the **VSB** (up/down) jumps to the next Monitor screen in a cyclic way.

Mute Hot Key (accessible from all menus and screens):

Touching button **A** or button **B** let you directly jump to the Signal Monitor. Here you can mute/unmute each channel directly by touching button **A** or button **B** again. After adjustment you can step back to the previous screen by touching the **MENU** button.

Home Menu Hot Key (accessible from all menus and screens):

Touch and hold **MENU** (≈ 2 s) let you directly jump to the Home Menu. You can step back to the previous screen by touching the **MENU** button. The Home Menu can be defined individually in the Display menu section.

Quick Access Menu Hot Key (accessible from all menus and screens):

Touch and hold **ENTER** (≈ 2 s) let you directly jump to the Quick Access Menu. You can step back to the previous screen by touching the **MENU** button.

The Quick Access Menu (QA Menu) can be defined individually in the Display menu section.

4.2 Power On / Off

As soon as the **V8** amplifier is connected to the mains it will start up the internal operating system. After a few seconds the display will shortly show the **V8** logo followed by the Power On-Screen (if the amplifier has been previously switched off).

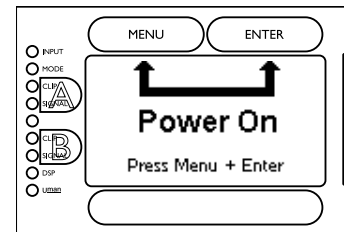

This is the screen used to switch the amplifier On/Off. Please touch **MENU** and **ENTER** simultaneously to switch the amplifier on.

To power off the **V8** either navigate to the **Power** menu or use the Power Off Hot Key (see chapter Hot Key Functions). Touch and hold **MENU** and **ENTER** simultaneously for a few seconds. This will display the power off confirmation window.

Now pressing **ENTER** once will finally switch off the amplifier.

NOTE: Turning the Amplifier off does NOT disconnect the amplifier from mains. See also chapter 3.3.

4.3 Indicators

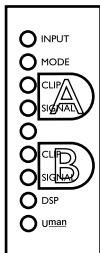

Input Selection LED
 Output Mode LED
 Clip LED Channel A
 Signal LED Channel A
 Device Identifier LED
 Clip LED Channel B
 Signal LED Channel B
 DSP LED
 Uman LED

4.3.1 Input Selection LED

The status of the bi-coloured (green/orange) LED changes between off, green, and orange depending on the selected input (see 3.4).

- LED is off – Analog inputs active
- LED lit green – Digital (Uman) inputs active
- LED lit orange – Digital AES input is active

4.3.2 Output Mode LED

The status of the bi-coloured (green/orange) LED changes between off, green, and orange depending on the selected Output Mode (see 3.6).

- LED is off – Dual Channel operation
- LED lit green – Mono Bridge operation
- LED lit orange – Parallel Mono operation

4.3.3 Clip LEDs (Channel A/Channel B)

This LED indicates an overloading of the corresponding amplifier channel.

4.3.4 Input Signal LEDs (Channel A/Channel B)

The green Signal LED is illuminated when the input signal level is sufficiently high for creating an output voltage of approx. 4 V; this corresponds to an output power of approx. 4 W over a 4 Ω load.

Note that these LED's are only driven by the input signal level, and will therefore also be active if the output channels are muted or the attenuation is set to maximum (–127,5 dB).

4.3.5 Device Identifier LED

This white coloured LED helps you to identify an amplifier in a large Uman network. By activating the Identify Device function in Uman software, the Device Identifier LED of the corresponding amplifier will flash in a bright white.

Attention: avoid looking directly into the LED when near the amplifier!

4.3.6 DSP LED

The green DSP LED is illuminated when the internal DSP is routed into the signal path. With the DSP-Board installed you can route the DSP into the signal chain (DSP On) or bypass the complete DSP section (DSP Off). For more information regarding DSP functionality and Remote Control of the Amplifier please visit www.camcoaudio.com.

4.3.7 Uman LED

This green LED is illuminated when the amplifier's input source is set to Uman.



4.4 Main Menu

Once that amplifier has been turned on, the main menu offers six items:

- The **Power** menu is used for switching the amplifier off.
- The **Settings** menu offers control of all important amplifier settings.
- The **Monitor** menu gathers different screens carrying information about the current operating state of the amplifier like for example output signal levels, loaded presets, limiter, input and network settings, temperature status and more.
- The **Display** menu offers control of the display brightness and contrast, allows to define the Home and Quick Access Menus and more.
- The **Lock Device** menu allows to temporarily disable the touch-sensitive elements to prevent unintentional changes.
- The **System Info** menu displays for example the amplifier serial number and firmware release version number

Please consult the **V8** Navigation Guide for details about all different menus, screens and options. You can always find the current **V8** Navigation Guide on our website www.camcoaudio.com.

4.5 Power Amp Protection Systems

4.5.1 Clip Limiter

If the maximum output level is larger than the amplifier can deliver, the Clip Limiter (if active) will reduce the output signal in order to limit distortion. The clip limiter algorithm works in a forward driven and clip signal dependent approach.

The Clip Limiter works on each channel independently (except for the two mono-operation modes). The Clip Limiter has three different modes (Off, Slow and Fast) which can be selected in the settings menu.

The Clip LED sensitivity on the display is designed to be very responsive and accurate. This means that you will still see the Clip LEDs light up, even if the clip limiter is working correctly. This allows the user still to assess if there is real clip, even if the clip limiter does prohibit audible distortion. The remaining (and indicated) clip is then very small and usually low enough to be audibly perceive as "clean" or undistorted signal, compared to a disabled clip limiter.

4.5.2 SOA Protection

To ensure that the power transistors are only used in the Safe Operation Area (SOA), the SOA-protection would mute the corresponding channel if not. If the power transistors are back in their SOA, the channel is automatically unmuted again.

4.5.3 Thermal Protection

The microprocessor uses several sensors on the amplifier's heatsinks in order to ascertain temperature data. If the microprocessor detects a temperature of more than 85 °C at the amplifier's heat sinks, the input signal on that channel is automatically reduced. If the temperature exceeds 95 °C, the corresponding channel is muted. If the temperature exceeds approx. 100 °C, the main SMPS is switched off as an emergency protection. The thermal protection status of the amplifiers are indicated in the signal monitor section of the display.



4.5.4 DC Protection

Each output of the power amp is constantly monitored for persistent DC voltage levels. If the 10 V threshold voltage is exceeded at any of the outputs, the corresponding channel will be automatically switched off. A DC issue can be located in the output stage, the driver stage, or at the input of the amplifier.

Output Stage

When a persistent DC voltage is located at an output stage, the main SMPS will be permanently switched off. This will be indicated on the display.

Driver Stage/Amplifier Input

When a DC voltage is located at the driver stage or the input stage, only this channel's output stage is muted and the volume set to zero. The other channel continues to operate normally. After a short time the channel is unmuted again and the volume increased again. This will be shortly indicated in the Signal Monitor section. of the display

4.5.5 DC Servo

To prevent DC Offset at the speaker output, the **V8** amplifiers are fitted with two DC Servos (hence there are no capacitors in the signal path!).

4.5.6 Overcurrent Protection

The output stage is permanently monitored for possible current surges. There are two limiting levels of overcurrent depending on output voltage. These limits will be set automatically. This improves reliability without degrading sound quality when driving complex loads.

4.6 Mains Protections

4.6.1 Inrush Current Limitation

Within 2 seconds of the **V8** amplifiers being connected to the mains, the inrush current limiter will charge the primary capacitances in a controlled way, limiting the maximum mains current during startup.

4.6.2 Mains Overvoltage Detection

The mains overvoltage detection is always operative. When the mains voltage exceeds approx. 267 V (230 V operation), or 134 V (120 V operation) the amplifier will switch off. When the mains voltage returns to nominal value, a soft start occurs.

4.6.3 Mains Surge Overvoltage Protection

The **V8** is fitted with a varistor unit, protecting the SMPS from sporadic surge overvoltages coming from the mains distribution.

If active, this protection is indicated by an orange LED behind the dust cover (on the right side). If this LED is not lit, this means that the amplifier has already suffered significant overvoltages surges and that the varistor protection needs to be exchanged.

4.6.4 Mains Failure Detection

Mains Failure Detection is always operative. When the mains supply is interrupted for approx. more than 4 mains cycles, the amplifier will detect and display a mains voltage loss. When the mains voltage returns to a normal value, a soft start occurs and the amplifier returns to normal/previous operation.



4.6.5 Fuse Protection

When driving the **V8** at very high output levels over a longer period of time (i.e. several seconds and minutes) the average mains current draw can become very high. In such situations, the FuseProtect limiter will reduce the output signal in order to prevent the external mains breaker from tripping. But this limiter in turn will not affect the output signal on dynamic music signal and short current peaks, thus guaranteeing the full available peak output power.

Due to the very large output power of the **V8**, this limiter has been set to a maximum average mains input current of approx. 24 A.

This design choice has been made to achieve the best compromise between mains breaker tripping protection and long term output power capabilities of the **V8**. This choice allows the **V8** to deliver more output power over a longer time period, which it is easily capable of.

But in turn this also means that mains breaker tripping still *can* occur when driving the **V8** at very high output levels over a longer time period.

If repeated mains breaker tripping is an issue, the **V8** offers the possibility to reduce the average mains current level down to 8 A if needed (in 1 A steps). Typically a value of 18 A is safe for use with a 16 A C-type mains breaker.

Please note that the FuseProtect limiter only controls the average mains input current, not the short term peak input current. This means that with very dynamic music signals the (short term) input current can still reach very high levels, which can be very demanding for a mains distribution, even with this limiter set to low values. See also *chapter 3.3.3*.

If active, this limitation is indicated in the display's Signal Monitor and also by a red LED behind the dust cover (approx. in the top middle of the dust cover).

4.7 Main SMPS Protections

4.7.1 Overcurrent Protection

Main SMPS (Switched Mode Power Supply) transformer current of your **V8** amplifier is continuously monitored. If over current occurs, the main SMPS immediately stops working. Should there be an internal failure, this feature prevents other parts being damaged.

4.7.2 Overload Protection

In case of extremely high output levels with heavily clipped output signals and low loudspeaker impedances $< 3 \Omega$, this additional protection will reduce the amplifier stage output current limitation very quickly. If activated, this indicates that the amplifier is running close to its absolute maximum power capacity. In normal operation (no clipping or only slight clipping) this protection should never be activated.

If active, this protection is indicated by a white LED behind the dust cover (on the top left side of the dust cover).

NOTE: Please reduce the input level if you see this LED flashing.

4.7.3 Thermal Protection

The temperature of the main SMPS transformer of your **V8** amplifier is permanently monitored. If the temperature exceeds 85 °C, the main SMPS is switched off. The amplifier's display will indicate a main SMPS error in this case.

4.8 Fans

The fans mounted in your **V8** amplifier operate permanently, but as long as the temperature remains below 40 °C, they run at their slowest speed and can hardly be heard. The highest detected temperature from either channel controls the speed of the fans. Above 40 °C the speed is increased until it reaches its maximum value.

4.9 Internal LED Description

This section describes the internal status-LEDs which can be seen from the front behind the dust filter. These status LEDs can be helpful for troubleshooting in case of an unexpected amplifier behaviour.

Note that the picture shows the internal LED's of newer amplifier versions (production date > Q3/2012).

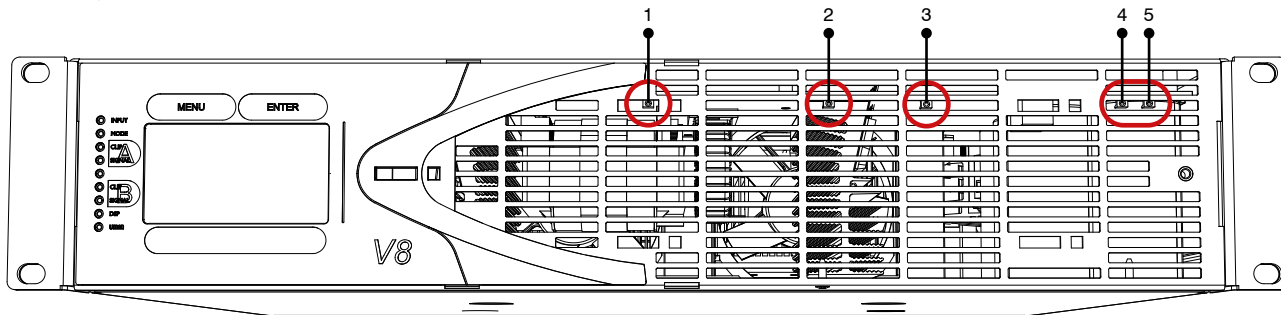

1. Overload Protect limiter LED:

This white LED will flash if the Overload Protection Limiter is activated. Please see chapter 4.7.2 for more details.

2. FuseProtect limiter LED/Mains supply status indicator LED:

During normal operation, this red LED indicates that the FuseProtect limiter is activated. Please see chapter 4.6.5 for more details.

Additionally, if the amplifier has been powered down (standby), this LED indicates the status of the mains:

SMPS/Amplifier Off (standby) and FuseProtect LED On: Bad mains voltage or no mains voltage at all
 SMPS/Amplifier Off (standby) and FuseProtect LED Off: Mains voltage OK

3. SMPS On-LED:

This green LED will be constantly on as long as the main SMPS inside the amplifier is working. If the amplifier has been powered down (standby) this LED will be slowly pulsating, indicating that the SMPS is off but ready to be switched on again at any time.

4. ICL On-LED:

This green LED indicates that the ICL (Inrush Current Limitation) is working properly. This LED should always be on as long as the amplifier is connected to the mains (even if powered down or in standby). If this LED is not on although the amplifier is connected to mains then please check your mains distribution.

See also chapter 3.3.2 and 4.6.1 for more details.

5. Mains Surge Overvoltage Protection LED:

This yellow/orange LED indicates that the surge overvoltage protection is still active. Please see chapter 4.6.3 for details.

Older amplifiers (production date < Q3/2012):

For all older amplifiers please note that the white Overload Protection LED is missing. Additionally, the SMPS-On-LED and the FuseProtect-LED are oriented in a different direction, so that they might not be easily visible when facing the amplifier. But if you look slightly from the bottom (as on the picture) these LED's should still be clearly visible.

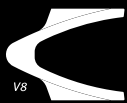

4.10 Filter Cleaning

The air intake on the front of your **V8** amplifier is fitted with a removable filter system. If the filter becomes clogged, the unit will not cool as efficiently as it should and may result in reduced output levels.

For changing the filter, no tools are required: first, gently slide the whole plastic filter assembly a few millimeters to the left and lift it from the front panel. Next, beginning on one of the long sides, carefully unclip the molded surround (4) from the cradle (2) and then carefully pull the **CAMCO** badge (5) out of the four fastening holes with both hands. Remove the foam filter (3) and clean it with a mild dishwashing detergent and warm water. Once dry, replace the foam filter carefully into the cradle and repeat the dismantling procedure in reverse. Insert the five pins on the filter frame into the clip apertures (1) and slide the filter carefully to the right to secure.

V8 Filter Assembly

- 1 Clip Aperture
- 2 Injection Molded Cradle
- 3 Foam Filter
- 4 Injection Molded Surround
- 5 Injection Molded **CAMCO** Badge

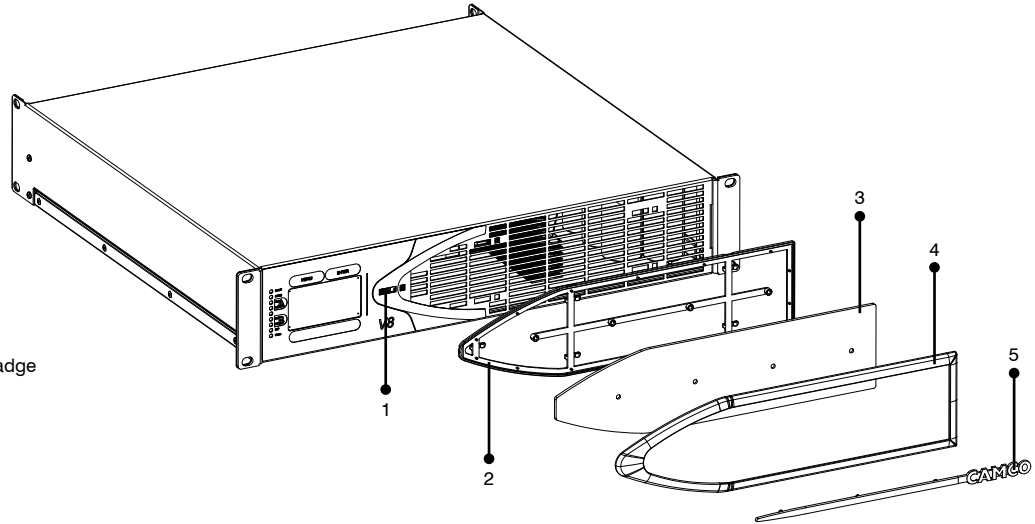



<p>Output Power 1 kHz, THD ≤ 1%, in dual channel operation <small>typical values @ 230 V / 50 Hz duration limited by fuse/thermal protection for RL<=8 Ω</small></p>	<p>1250 W @ 16 Ω 2300 W @ 8 Ω 4000 W @ 4 Ω 5100 W @ 2 Ω</p>				
<p>Peak Output Power 1 kHz, single sine wave in dual channel operation <small>typical values, may be subjected to component tolerances</small></p>	<p>1250 W @ 16 Ω Peak 2500 W @ 8 Ω Peak 4900 W @ 4 Ω Peak 5300 W @ 2 Ω Peak</p>				
<p>Mono Bridge and Parallel Mono Operation Output Power 1 kHz, THD ≤ 1%, in mono bridge operation <small>typical values @ 230 V / 50 Hz duration limited by fuse/thermal protection for RL<=16 Ω</small></p> <p>1 kHz, single sine wave in mono bridge operation <small>typical values, may be subjected to component tolerances</small></p>	<table border="0"> <tr> <td data-bbox="906 384 1225 473"> <p>Mono Bridge 4600 W @ 16 Ω 8000 W @ 8 Ω 10200 W @ 4 Ω</p> </td> <td data-bbox="1232 384 1505 473"> <p>Parallel Mono 4600 W @ 4 Ω 8000 W @ 2 Ω 10200 W @ 1 Ω</p> </td> </tr> <tr> <td data-bbox="906 496 1225 563"> <p>5000 W @ 16 Ω Peak* 9800 W @ 8 Ω Peak* 10600 W @ 4 Ω Peak*</p> </td> <td data-bbox="1232 496 1505 563"> <p>5000 W @ 4 Ω Peak* 9800 W @ 2 Ω Peak* 10600 W @ 1 Ω Peak*</p> </td> </tr> </table>	<p>Mono Bridge 4600 W @ 16 Ω 8000 W @ 8 Ω 10200 W @ 4 Ω</p>	<p>Parallel Mono 4600 W @ 4 Ω 8000 W @ 2 Ω 10200 W @ 1 Ω</p>	<p>5000 W @ 16 Ω Peak* 9800 W @ 8 Ω Peak* 10600 W @ 4 Ω Peak*</p>	<p>5000 W @ 4 Ω Peak* 9800 W @ 2 Ω Peak* 10600 W @ 1 Ω Peak*</p>
<p>Mono Bridge 4600 W @ 16 Ω 8000 W @ 8 Ω 10200 W @ 4 Ω</p>	<p>Parallel Mono 4600 W @ 4 Ω 8000 W @ 2 Ω 10200 W @ 1 Ω</p>				
<p>5000 W @ 16 Ω Peak* 9800 W @ 8 Ω Peak* 10600 W @ 4 Ω Peak*</p>	<p>5000 W @ 4 Ω Peak* 9800 W @ 2 Ω Peak* 10600 W @ 1 Ω Peak*</p>				
<p>Circuitry</p>	<p>Hybrid Class H</p>				
<p>Signal to Noise-Ratio <small>22 Hz–20 kHz, 4 Ω load</small></p>	<p>>107 dB (unweighted) >110 dB (A-weighted)</p>				
<p>Power consumption @ 230 V <small>* both channels driven at 550 W output power (approx. ¼ of max. THD limited output power with pink noise to represent typical music signal)</small></p>	<p>Amplifier standby (power off): 8 W Idle (Amp powered on): 60 W 4 Ω: 1900 W* 2 Ω: 2100 W*</p>				
<p>Maximum output voltage <small>in dual channel operation; typical values, may be subjected to component tolerances</small></p>	<p>± 200 V peak</p>				
<p>Maximum output current <small>in dual channel operation; typical values, may be subjected to component tolerances</small></p>	<p>± 72 A peak</p>				



Frequency Response @ 4 Ω load with 120 W output power	20 Hz – 20 kHz: ± 0,07 dB
THD + N over frequency @ 4 Ω load with 120 W output power	20 Hz – 17 kHz: <0,1%
Damping Factor 8 Ω load, 1 kHz and below	>400
Input Impedance	22 kΩ balanced
Input Gain	Selectable: 26 dB, 32 dB or 1,4 V input sensitivity
Maximum Analogue Differential Input Level	+22 dBu/9,75 Vrms/13,8 Vp
Level Attenuation	0 dB to –127,5 dB in increasing step width, from 0,5 dB (high end, 0 dB) to 20 (low end, –127,5 dB)
Minimum Loudspeaker Load Impedance <small>lower values are safe, but out of specification no performance guarantees can be given when driving lower impedances than specified</small>	Zmin = 2 Ω for Dual-Channel operation Zmin = 1 Ω for Parallel Mono operation Zmin = 4 Ω for Mono Bridge operation
Protection Circuits	Inrush-current limitation, protection circuits against power on/off transients, temperature monitoring of transformers and heatsinks, output DC protection, temperature dependent SOA protection, intelligent mains fuse protection, SMPS overload protection, overcurrent limitation, thermal limitation
Limiters	Selectable Clip Limiter, selectable FuseProtect Limiter
Cooling	Two temperature dependent speed-controlled axial fans
LED Indicators	LEDs for Input Selection, Output Mode, Clip, Signal, Device Identification, DSP, and Uman
Input Connectors	Two 3-pin XLR female analogue input connectors, pin 2 = hot (inphase) Two 3-pin XLR male passive loop through connectors One 3-pin XLR female AES (digital) input connector Two Uman network connectors (in and out) etherCON® RJ45 One Ethernet Link connector RJ45
Power Output Connectors	One 4-pole SPEAKON® connector for each output channel (bi-amping possible)
Modes of Operation	Dual channel (Stereo), mono bridge and parallel mono
Input Sources	Analogue, AES, Uman network
A/D – D/A Converters	24 bit/96 kHz

We reserve the right to make technical alterations without prior notice



Latency

Zero-latency mode in analog input mode (with DSP off). Pure analog signal path.
 Approx. 0,4 ms with DSP off and AES or Uman input
 Min. 1,15 ms with DSP on and AES or Uman input
 Min. 1,56 ms with DSP on and analog input

Digital Inputs

AES – EBU, 16, 18, 20, or 24-bit, 32 – 96 kHz with selectable sample rate converter
 Uman digital audio network

AC mains

*: Approximate mains voltage ranges where the amplifier can be used. Amplifier output power performance will decrease with lower mains voltages than the rated 230 V/120 V and slightly increase with higher mains voltages.

Dual-voltage SMPS with automatic voltage range selection 230 V/ 120 V, 50–60 Hz
 Operating voltages*: 230 V range: 180 – 267 V, 120 V range: 70 – 134 V
 Neutrik 32 A powerCON® connector
 Selectable FuseProtect limiter to control long-term average mains input current from 8 to 24 A

Operating Temperature

+5 °C to +55 °C

Dimensions (W × H × D)

483 × 88,1 × 452,5 mm / 19 × 3,5 × 17,2 inches (19", 2U)

Net Weight

13 kg / 28,7 lbs

Shipping Dimensions (W × H × D)

615 × 135 × 540 mm (0,045 m³) / 21,3 × 5,3 × 24,2 inches

Shipping Weight

15,6 kg / 34,4 lbs

We reserve the right to make technical alterations without prior notice

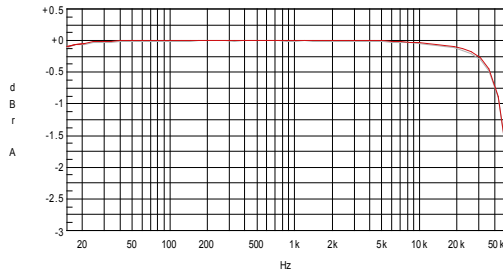

Figure 6.1

Gain vs. frequency, 120 W output power, 4 Ω (channel 1, channel 2)
(Measurement of a typical performance)

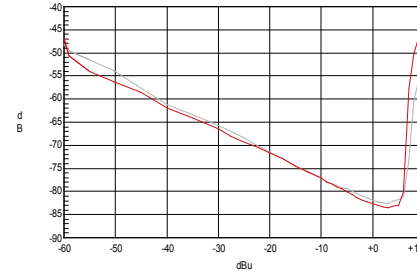

Figure 6.3

THD @ 1 kHz, 2 Ω vs. input voltage (channel 1, channel 2)
(Measurement of a typical performance)

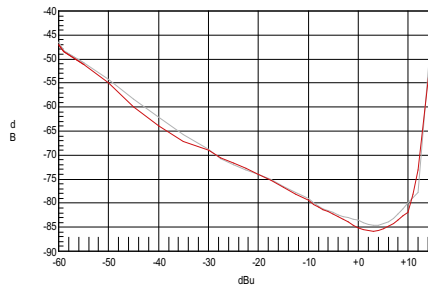

Figure 6.2

THD @ 1 kHz, 4 Ω vs. input voltage (channel 1, channel 2)
(Measurement of a typical performance)

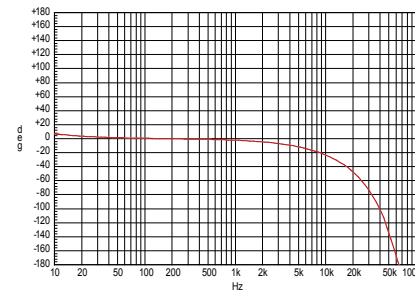

Figure 6.4

Phase vs. frequency (channel 1, channel 2)
(Measurement of a typical performance)

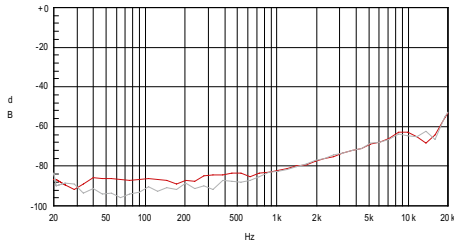

Figure 6.5

THD vs. frequency, 120 W output power, 4 Ω (channel 1, channel 2)
(Measurement of a typical performance)

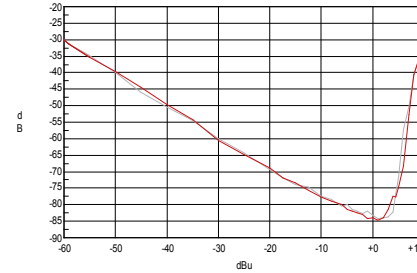

Figure 6.7

DIM 100 intermodulation distortion @ 4 Ω vs. input level (channel 1, channel 2)
(Measurement of a typical performance)

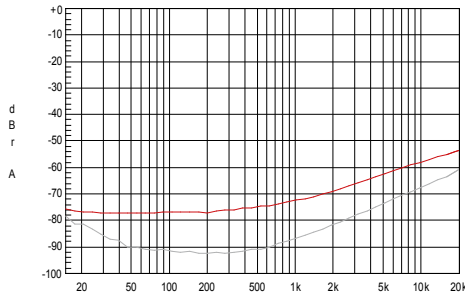

Figure 6.6

Channel separation vs. frequency @ 250 W / 2 Ω (channel 1, channel 2)
(Measurement of a typical performance)

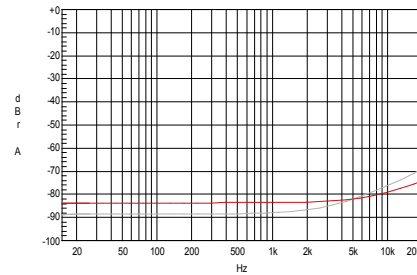

Figure 6.8

Common mode rejection ratio (channel 1, channel 2)
(Measurement of a typical performance)

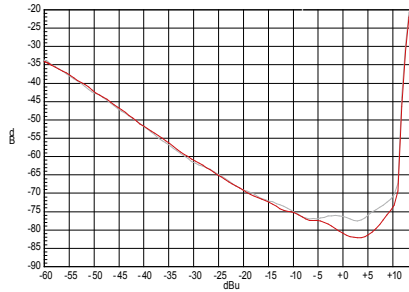

Figure 6.9

SMPTE intermodulation distortion (60 Hz and 7 kHz) @ 4 Ω vs. input level
(channel 1, channel 2) (Measurement of a typical performance)

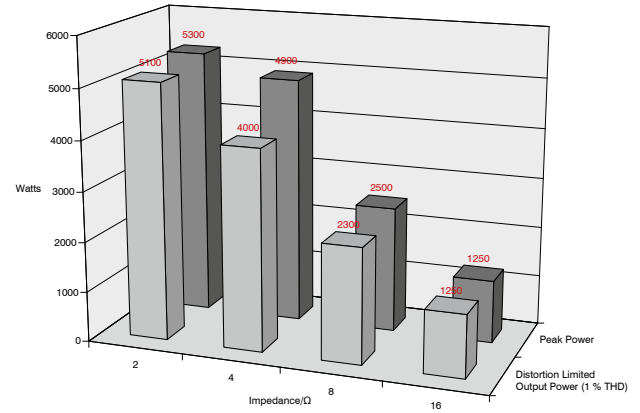

Figure 6.10

V8 (Measurement of a typical performance)



7.1 Summary of Warranty

CAMCO guarantees the **V8** Amplifier to be free from defective material and/or workmanship for a period of six (6) years from the date of sale. When a defect occurs under normal installation and use, **CAMCO** will repair the product under this warranty. In this event, please return the amplifier to your dealer/distributor together with a copy of your sales receipt as proof of purchase.

This warranty provides that examination of the returned product must indicate in our judgement a manufacturing defect.

7.2 Items Excluded from This Warranty

CAMCO is not liable for any damage caused by shipping accidents, misuse, abuse, operation with incorrect AC voltage, operation with faulty peripheral equipment, modification or alteration without prior factory approval, service by an unauthorized service center and normal wear and tear. Amplifiers on which the serial number has been removed or defaced are not eligible for warranty service.

7.3 What **CAMCO** Will Do

CAMCO (or its appointed agent) undertakes to rectify any defect regardless of the reason for failure (unless excluded from this warranty), by repair, replacement or refund as it sees fit.

7.4 How to Obtain Warranty Service

You must notify your dealer/distributor of your need for warranty service. All components must be shipped in the original packaging.

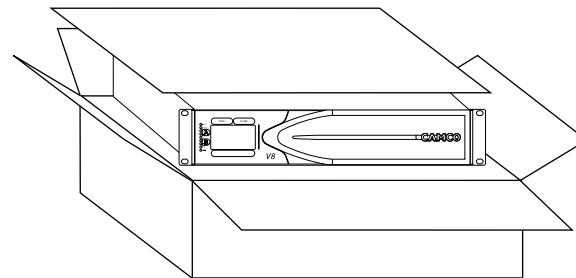

7.5 **CAMCO's** Product Improvement

CAMCO reserves the right to improve the technical standard of its products without giving prior notice. If in any doubt, please consult your dealer/distributor or contact **CAMCO** directly for clarification.



**PLEASE ENCLOSE THIS COMPLETED FORM WITH THE AMPLIFIER
DO NOT SEND SEPARATELY**

Owner's Information

Company Name: _____

Contact: _____

Address: _____

Telephone: _____

Facsimile: _____

eMail Address: _____

Model: _____

Serial Number: _____

Purchase Date: _____

Nature of problem occurred

Please describe the conditions that existed when the problem occurred and what attempts were made to correct it: _____

Expired Warranty

If the warranty has expired, payment will be:

Cash/Cheque

VISA

MasterCard

Other equipment in your system: _____

Shipping Address

To transport the amplifier, the original packing materials must be used. Please return the amplifier to the following address or your nearest CAMCO appointed distributor.

Our web site: www.camcoaudio.com provides a complete list of CAMCO dealers/distributors.

CAMCO Produktions- und Vertriebs-GmbH für Beschallungs- und Beleuchtungsanlagen, Fischpicke 5, 57482 Wenden, Germany





9 Maintenance Information

Cleaning and servicing the inside of the amplifier must never be carried out by unqualified personnel. The amplifier must never be opened by unqualified personnel.

Cleaning and servicing work on the inside of the amplifier must only be carried out by qualified personnel.

Qualified personnel is defined as a person who has gained specialised relevant knowledge of electronic engineering through education, training, and experience, and who has sufficient knowledge of all relevant governmental work safety regulations to be in a position to judge the safe functioning of power amplifiers based on technical rules according to IEC 60065 (IEC 60065 (DIN EN 60065) "Safety Requirements for Audio, Video or similar Electronic Appliances").

In order to guarantee the safe functioning of the amplifier, it has to be checked regularly, depending on its application but at least once a year, by a properly qualified person.

Advice on how to carry out these checks can be found in DIN VDE 0702-1 "Safety Checks for Electronic Appliances" .

An amplifier that is considered to be unsafe must be labelled accordingly and stored in a safe place to prevent this amplifier being used mistakenly.

10 Decommissioning

During the decommissioning process of the amplifier, all legally prescribed rules and procedures must be adhered to.



CAMCO

VORTEX
SILVER SERIES

COMPANY INFORMATION

Mailing Address:

CAMCO Produktions- und Vertriebs-GmbH
für Beschallungs- und Beleuchtungsanlagen
Fischpicke 5
57482 Wenden
Germany

Telephone:

+49 (0) 27 62 408 - 0

Facsimile:

+49 (0) 27 62 408 - 10

Internet:

www.camcoaudio.com

Email:

postmaster@camcoaudio.com

CAMCO

www.camcoaudio.com